



**A770** | Compact Loaders



## Machine Rating

Rated operating capacity (ISO 14397-1)	1550 kg
Tipping load (ISO 14397-1)	3100 kg
Pump capacity	87.1 L/min
Pump capacity (with high flow option)	151 L/min
Steering pump	51.5 L/min
System relief at quick couplers	23.8–24.5 MPa
Max. travel speed — low	11.4 km/h
Max. travel speed — high	19.8 km/h

## Engine

Make / Model	Kubota / V3800-DI-T-E3
Fuel/ Cooling	Diesel/ Liquid
Power	68.6 kW
Torque at 1600 RPM (SAE J1995 Gross)	315 Nm
Number of cylinders	4
Displacement	3769 cm <sup>3</sup>
Fuel tank	103 L

## Weights

Operating weight	4291 kg
------------------	---------

## Controls

Vehicle steering	Direction and speed controlled by two hand levers or joysticks (optional).
Loader hydraulics tilt and lift	Right-hand joystick (SJC)
Front auxiliary (standard)	Electrical switches on right-hand joystick

## Drive System

Transmission	Infinitely variable tandem hydrostatic piston pumps, driving two fully reversing hydrostatic motors
--------------	---

## Standard Features

Two-speed travel	Hydraulic bucket positioning
High-back adjustable suspension seat	Instrumentation
Automatically activated intake air heater	Lift arm support
Bob-Tach™ frame	Parking brake
Bobcat Interlock Control System (BICS)	Seat belt
Deluxe operator cab Includes interior cab foam, side, top and rear windows	Seat bar
Dual steering mode: All-Wheel Steer (AWS) and Skid-Steer (SSL)	Turbo-charger with approved spark arrestor
Work lights, front and rear	12 x 16.5, 12-ply, Bobcat Heavy duty tyres
	CE certification

\* Roll Over Protective Structure (ROPS) – meets requirements of SAE-J1040 and ISO 3471; Falling Object Protective Structure (FOPS) – meets requirements of SAE-J1043 and ISO 3449, Level I

## Options

High-flow hydraulics	12 x 16.5, 12-ply, Bobcat Severe duty tyres
Power Bob-Tach™	12 x 16.5, 12-ply, Bobcat Severe duty tyres, poly fill
Air conditioning	12 x 16.5, 12-ply, Bobcat Solid flex tyres
Deluxe instrument panel	33 x 15.5-16.5, 12-ply, Bobcat Superflotation tyres
12 x 16.5, 12-ply, Bobcat Heavy duty tyres, offset rims	33 x 15.5-16.5, 12-ply, Bobcat Turf and Sand tyres

## Dimensions

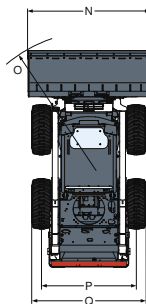
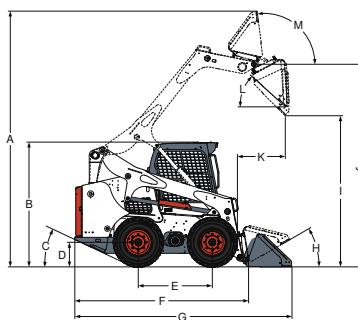

(A)	4232 mm	(J)	3353 mm
(B)	2065 mm	(K)	800 mm
(C)	25°	(L)	42°
(D)	207 mm	(M)	98°
(E)	1227 mm	(N)	1880 mm
(F)	2903 mm	(N)	2032 mm
(G)	3597 mm	(O)	3848 mm
(H)	30°	(O)	3386 mm
(I)	2649 mm	(O)	2179 mm
		(P)	1507 mm
		(Q)	1832 mm

## Attachments

- Angle / Snow blade
- Angle broom\*†
- Auger
- Bale forks
- Box blade
- Brushcat rotary cutter
- Buckets
- Wood Chipper\*
- Combination bucket
- Concrete pump\*
- Digger
- Dozer blade\*
- Drop hammer
- Dumping hopper
- Farm grapple
- Mower
- Flail cutter
- Forestry cutter
- Grader\*
- Hydraulic breaker\*\*
- Industrial grapple
- Landplane
- Landscape rake
- Pallet forks – heavy duty
- Pallet forks – hydraulic
- Planer\*
- Rear stabilisers
- Scarifier
- Snow V-blade
- Snow blower\*
- Sod layer\*
- Soil conditioner\*
- Spreader
- Stump grinder\*
- Super scraper
- Sweeper
- Tiller
- Tracks, steel
- Tree transplanter\*
- Trencher
- Utility forks
- Utility frame
- Vibratory roller
- Water kit
- Wheel saw
- Whisker broom

\*Attachment control kit required.

\*\*When operating the loader with this attachment, a Special Applications Kit, which includes a 12 mm Lexan front door with 6 mm top and rear windows, must be used.

†Optional water kit.



www.bobcat.eu